

MACHINE MODEL

SIRIO 315 SH

Heavy duty semiautomatic vertical saw

Short description

SIRIO 315 SH is the semiautomatic vertical disc saw for cutting from 0 ° to 45 ° right and from 0 ° to 60 ° left. SIRIO 315 SH is the ideal machine for cutting solid and steel profiles (also with high resistance)



Scan the video

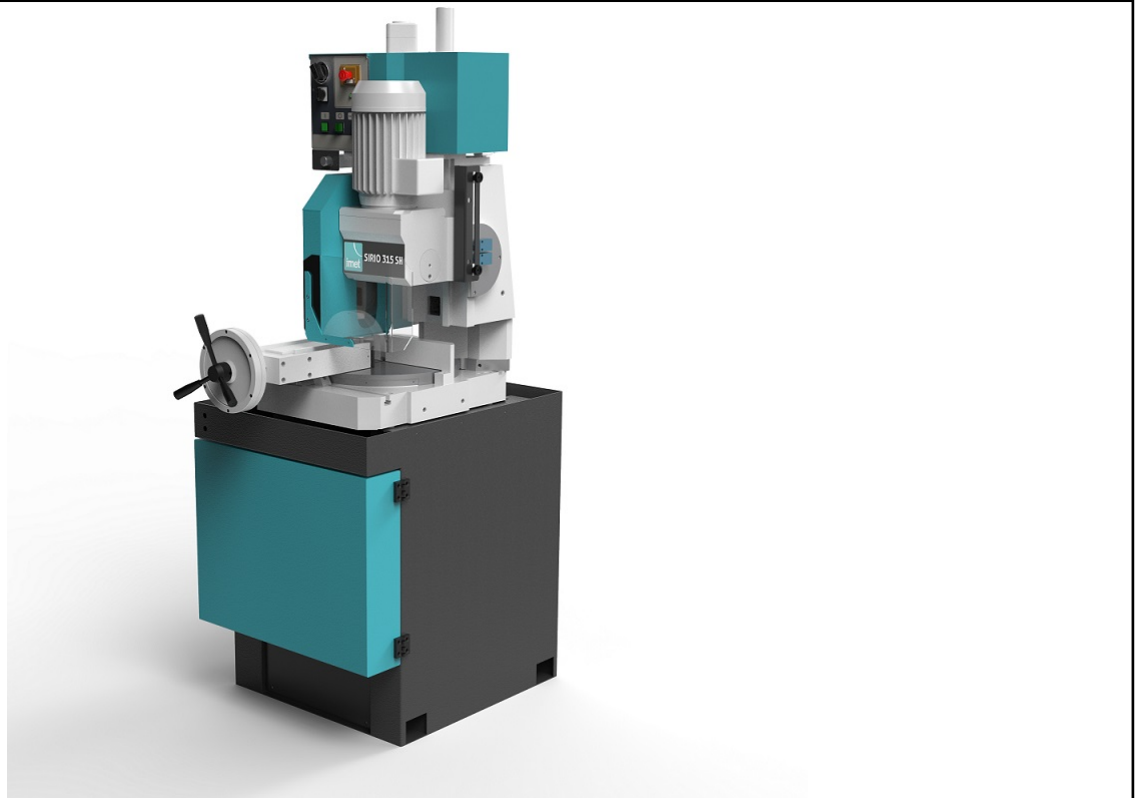

Cutting capacity at 0°	Tondo: 108mm - Quadrato: 93mm - Rettangolo: 150x90mm
Cutting capacity at 45° left	Tondo: 108mm - Quadrato: 93mm - Rettangolo: 105x80mm
Cutting capacity at 46° right	Tondo: 108mm - Quadrato: 93mm - Rettangolo: 105x80mm
Cutting capacity at 60° left	Tondo: 93mm - Quadrato: 80mm - Rettangolo: 75x90mm
Cutting capacity at 0° with 300mm blade	Tondo: 100mm - Quadrato: 84mm - Rettangolo: 140x80mm
Cutting capacity at 0° (solids)	60mm
Blade size	Diam.: 315mm
Blade speed	17/33 rpm
Blade doubled speed (optional)	33/66 rpm
Blade motor power	1.5/1.8 KW
Working table height	920mm
Dimensions	800x900x1950mm
Weight	360kg

Features



Structure

The SIRIO models have high structural stability to reduce vibrations and movements of the miter saw when cutting. The rigid vertical structure is in cast iron with a large surface of contact between the machine head and the structure to ensure even more solidity when in use



Cutting precision

SIRIO is equipped with a system with adjustable stops at 0 ° and 45 °, adjustable bar stop and graduated scale for other angles and maximum positioning precision.

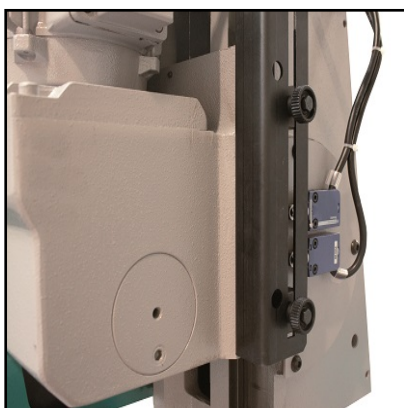

Start and end cut positions

The machine is equipped with a system to optimize the adjustment of the start / end cutting position thanks to two limit switches. Rapid ascent at the end of the cut.

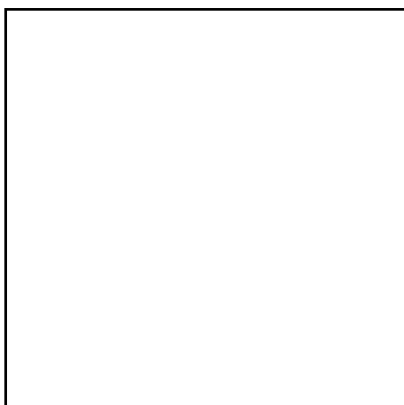

Pneumatic vice

The semi-automatic disc cutting-off machines Sirio are fitted as standard with the pneumatic front vice with material locking and transversal movement on the work surface.



V jaws (Optional)

OPTIONAL

Two pairs of cast iron V jaws to fittings bundles and round bars (max diameter 85 mm.) with tools to mount them

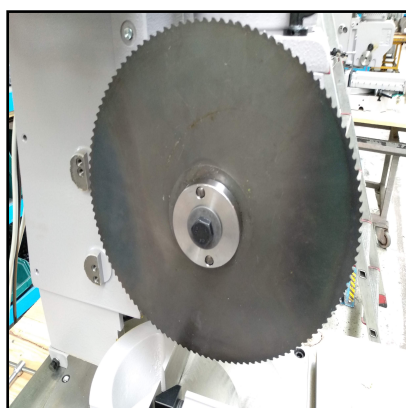

Blade (Optional)

OPTIONAL

SIRIO 315 SH can mount blade 315x2,5x40mm

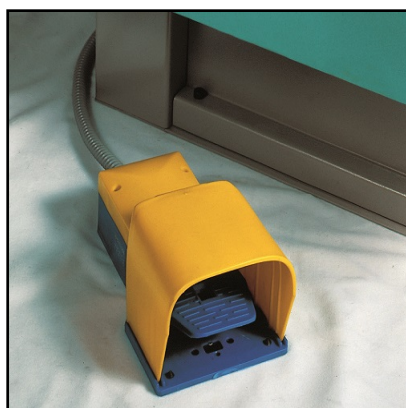

Foot pedal (Optional)

OPTIONAL

FOOT PEDAL+CABLE 3M + PLUG



Minimal lubrication system (Optional)

OPTIONAL

The lubrication system cancels the dispersion of the coolant without damaging or affecting the life of the blade. The system is equipped with a 1.3l tank and nozzle.



Adapter to synchronize the RTD/RTP table and Sitio (Optional) OPTIONAL

Adapter to synchronize the RTD/RTP table and the head motion



Loading/unloading roller table 1st unit (Optional) OPTIONAL

1st unit of roller conveyor compatible for both the loading and unloading sides. Length 2m, loading capacity 700kg.



Loading/unloading roller table follow.unit (Optional) OPTIONAL

Following unit of roller conveyor compatible for both the loading and unloading sides. Length:2m, loading capacity:600kg.

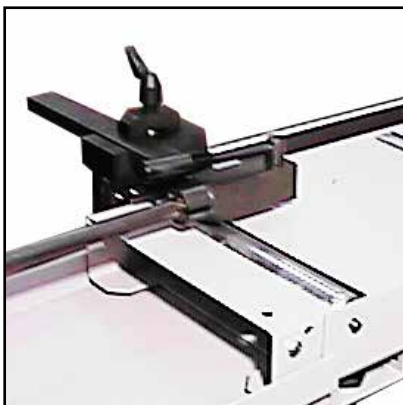

Unloading roller table with metric rod 1st unit (Optional) OPTIONAL

1° unit of roller conveyor (unloading side) with metric rod and length stop. Length: 2m, loading capacity 700kg.

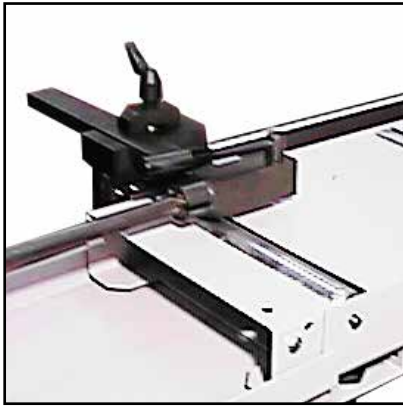

Unloading roller table with metric rod-follow.unit (Optional) OPTIONAL

Following unit of roller conveyor (unloading side) with metric rod and length stop.Length: 2m, loading capacity 600kg.



Unloading table with digital reading and manual positioning (optional) OPTIONAL

Unloading table with digital reading and manual positioning, you can choose lengths of 2mt., 4mt., 6mt., 8mt 10mt., 12mt.....



Unloading roller table with length stop (optional) OPTIONAL

Unloading roller table with length stop and selection of the lengths by means of a keyboard Available: -RTP3W30: Measuring length of 3m, 3 pedestals, max loading 3000kg; -RTP6w30: Measuring length of 6m, 5 pedestals, max loading 6000kg. etc..



Unloading roller table with digital reading and manual OPTIONAL

Unloading roller table with digital reading and manual movement. Available : - RTL3W30 Measuring length of 3m, 3 pedestals, max loading 3000kg; -RTL6KW30 Measuring length of 6m, 5 pedestals, max loading 6000kg. etc..



Vertical rollers (Optional)

OPTIONAL

Pair of containment vertical rollers 300 mm made in steel, max 2 pairs for each element 2 m long; to use without rollers cover (only for RTS) (not available together with RV-W30)



V rollers (Optional)

OPTIONAL

Pairs of V rollers made in steel for tubes, max 6 pairs per each element 2 m long, to be used on machines with V jaws, without rollers cover (only for RTS) (not available together with RI-W30) Pair of containment vertical rollers 300 mm made in steel, max 2 pairs for each element