

Instruction Manual

Workshop crane, CC10

Important: Read and understand this manual before use!

Instruction / Responsibility:

It is very important that the owner and the operator completely understand the operating manual and all its safety warnings before operating the workshop crane. It is important that the user has comprehended all instructions before use. The manufacturer of the crane is not liable for damages caused to people or things due to wrong- or irresponsible use of the crane.

Mounting:

Open the packages and check that the product has no damages caused by transportation and that all parts are enclosed. Withdraw the pin D by first removing the elastic pin C (fig. 1), lower the leg to horizontal position and insert the pin D and elastic pin C thoroughly again. Follow the same procedure with the other leg. Withdraw the elastic pin E, turn the parking arrangement (F) 180° to position the crane on its wheels as shown on (fig. 1). Insert the elastic pin (E) again and check that all bolts on the crane are tightened. Before operating the crane replace the oil plug (A) with the oilplug (B) with hole for bleeding as shown on (fig. 2.1) The oilplug (A) is for transport ONLY!

Operating instruction:

The crane is operated by activating the pump lever. (fig. 2.2) The arm is lowered again by turning the release handle slowly counter-clockwise. (fig.2.3) The release-handle is spring-loaded due to safety reasons. Test the crane first time by lifting without any load, then place the telescopic arm into the correct position according to the rated load (fig. 2.4) and test the crane with a load

WARNING! the max. lifting capacities for the different positions of the telescopic arm **MUST!** be complied with. These are stated on the maximum capacity diagrams on the telescopic arm.

WARNING! Safety instructions:

Do not overload the crane! Overload could result in damage to the crane or in worst case cause accidents! Before lifting-or transporting a load the operator **MUST!** take precautions that the load is not allowed to drop, and that the weight distribution is safe. The operator must before use take precautions that all pins are safely locked with split pins or lock rings.

This workshop crane is to be used at level and solid ground only. please see (fig. 2.5).

Always lower the load to the lowest possible position before transportation.

Important! the safety valve is calibrated and sealed by the manufacturer and it is **ABSOLUTELY PROHIBITED!** to open the seal or adjust its calibration. Offence against the above safety instructions could in worst case result in loss of the load which could cause personal injury and/or damage to the crane or properties. In case the crane has any irregularities, which could affect the safety, the crane must not be operated until it has been repaired.

Fig. 1.

CC10-L

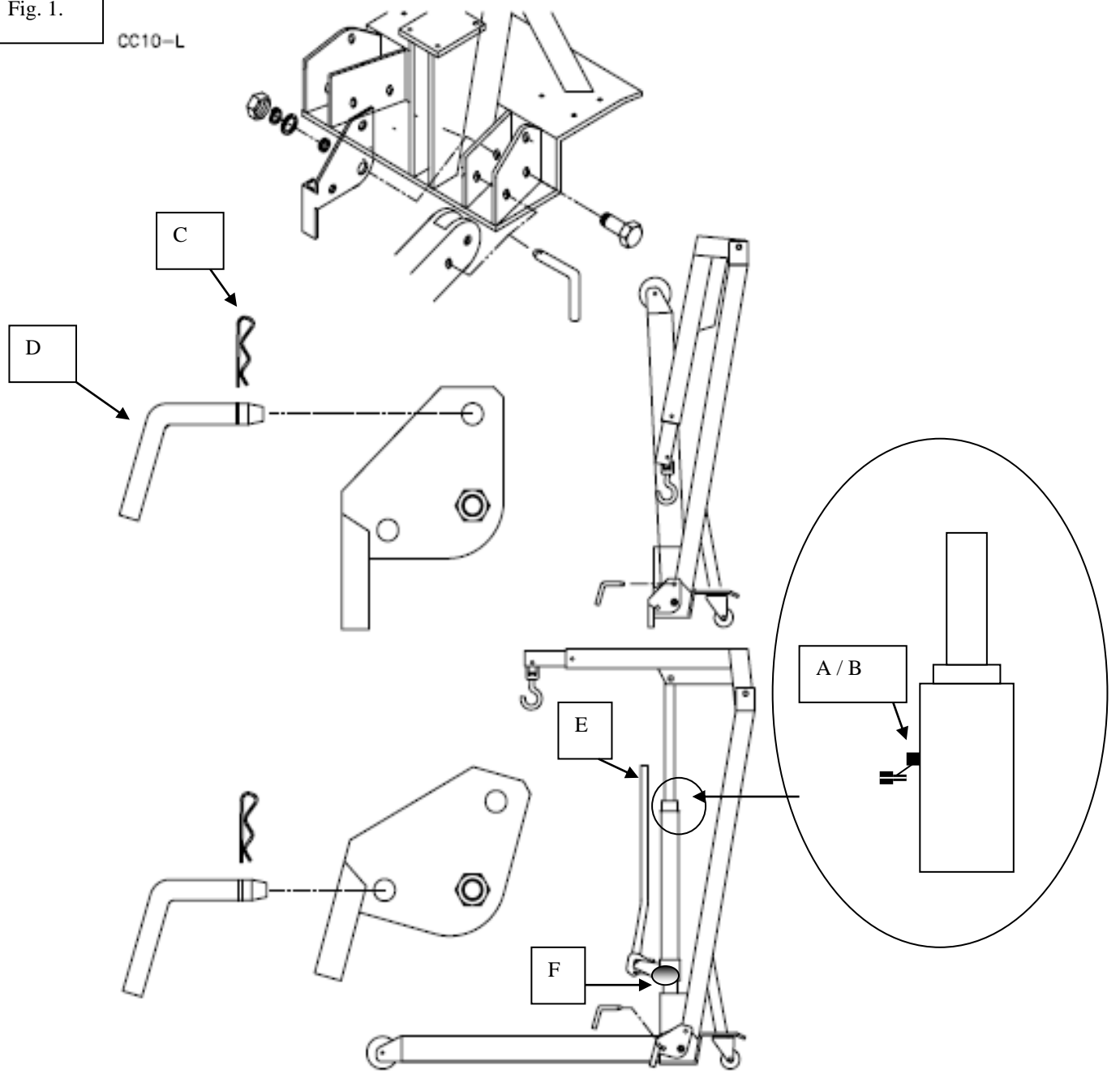
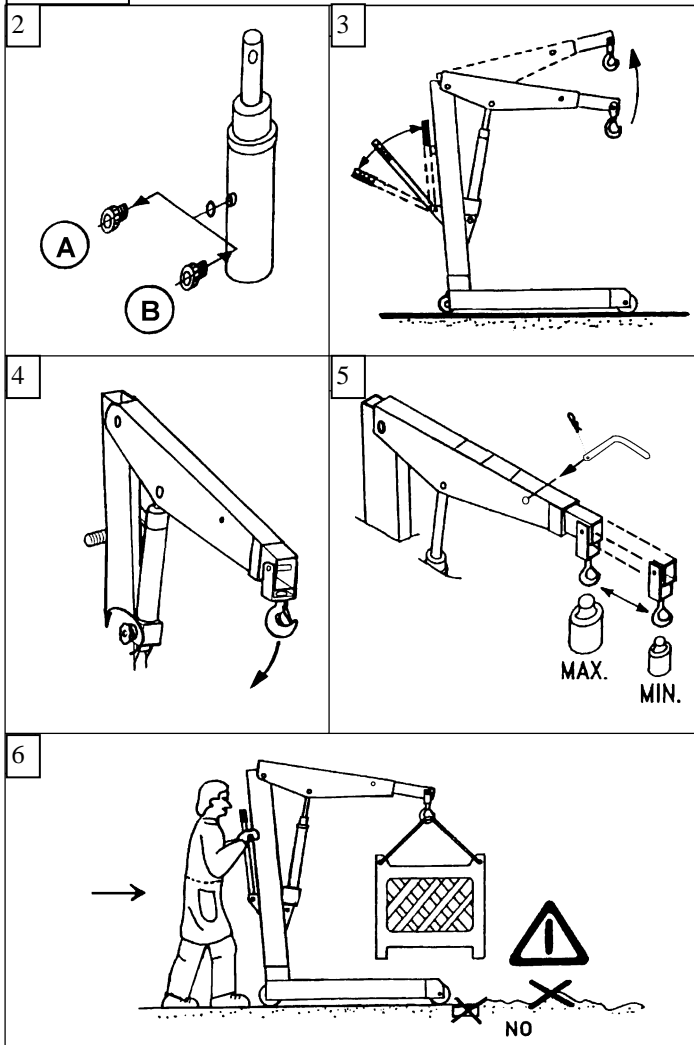
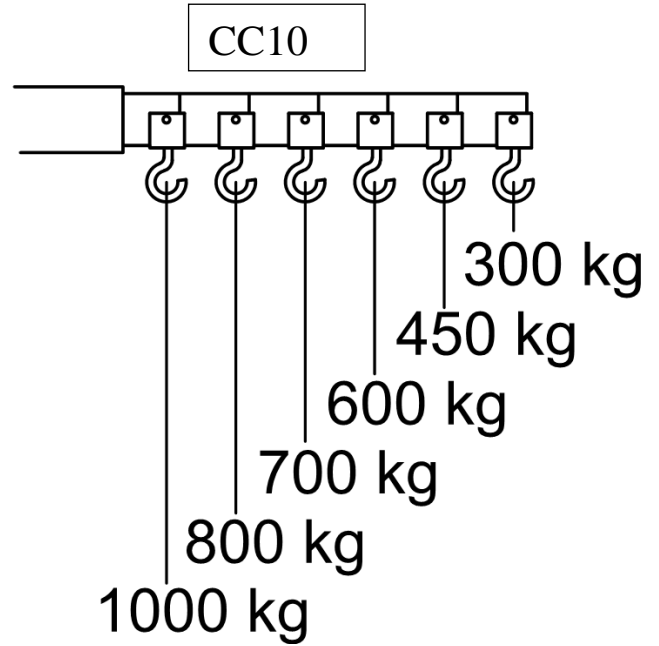

Fig. 2.



2.1.31004 2/2

2002.04.22



Maintenance:

At normal use all mechanical/moving parts only requires a monthly lubrication to be maintained. The pins must be greased every three months. Important! Use only oil or grease free from acid. An annual inspection must be performed by a skilled person. Every eventually worn out or defective part must be replaced with original spareparts. The owner and- or user must take precautions that repair is made by a skilled person. Before every use the operator must take precautions that there are no visible faults such as leaks, damage of the crane and loose or missing parts. In case the operator suspects that the crane has been overloaded or wrongly loaded it must before further use be inspected by a skilled person or an authorized workshop.

Oil quantity: 0.8 L. DO NOT use brake fluid or motor oil!

In case the hydraulic unit has a lack of oil or has been taken apart in order to replace the seals then fill up to the correct oil quantity. Activate the pump handle and add oil slowly through the filling hole at plug B. Warning! too much oil quantity might cause problems to the hydraulic system. Please note! Use only hydraulic oil with a gradation (viscosity) of ISO32 (CASTROL HYPIN AWS 32 or equivalent)

Decommissioning:

If the crane should ever be scrapped, draw off the oil into an approved container and dispose it at an approved authority.